

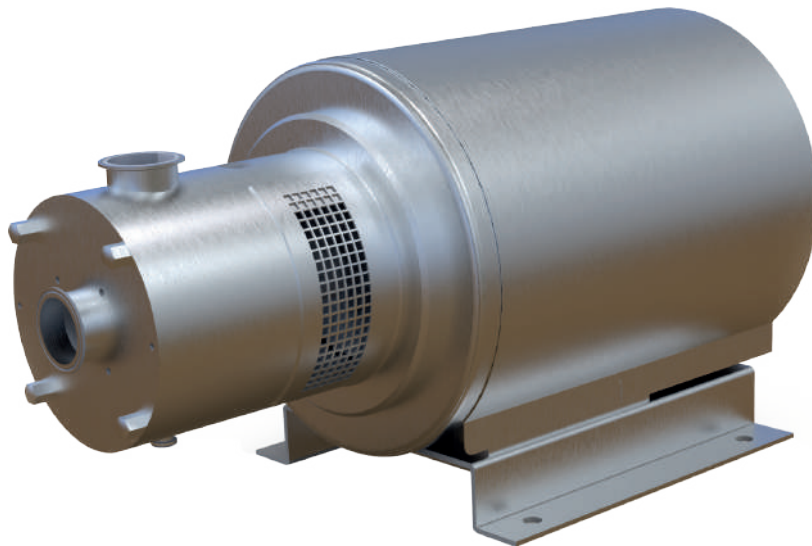

## **FIM INLINE MIXER**

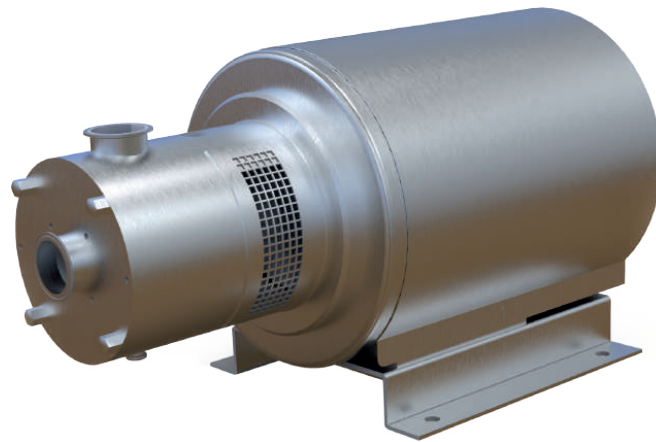

**YOUR SOLUTION PARTNER**



## FIM INLINE MIXER

### APPLICATION

The FIM series of the inline high shear mixers offers a possibility to pump, disperse, homogenize and emulsify products with one and the same equipment.

These mixers are especially useful in already existing plants.

They can work with a recirculation tank reaching the best efficiency after several passes of the product through the mixer.

Milk, beer, chocolate, syrup, cosmetics, fragrance, toothpaste, detergents, shampoo, shoe polish, soaps, Emulsifier, syrup, medicines, Paint, dyes, oil agents, etc.

### OPTIONS

- Cooled or pressurised mechanical seal.
- Baseplate with antivibration legs.
- Trolley with/without control panel.
- Mirror polish  $Ra < 0.5\mu m$  for the pharmaceutical applications.
- Other motor protections.

### MATERIALS

- Parts in contact with the product : AISI 316L
- Other stainless steel parts : AISI 304
- Mechanical seal Gaskets : C/SiC/EPDM
- Gaskets : EPDM
- Surface finish Ra :  $\leq 0,8\mu m$

### DESIGN AND FEATURES

- High shear, particle size reduction to less than 100 microns.
- Hygienic single mechanical seal.
- Various easily interchangeable working heads.
- Completely, easy to clean
- Standard connections: Clamp ISO-2852.
- Motor shroud.



**Slotted Head:**  
High shear and  
flow rate efficiency



**Disintegrating Head:**  
Higher viscosity products than  
any other

## WORKING PRINCIPLE

It is characterised by a high shear due to an adjustable tolerance between the rotor and the stator and the high speed of the rotor.

The product is suctioned through the inlet and the rotor pushes it to the stator.

Passing through the slots of the stator the product is mechanically sheared, the particles are sheared by the rotor at the speed of more than 20m/s.

And finally the flow is hydraulically sheared leaving the stator through the slots at a high speed.

If the viscosity of the product is higher than 200cP, it is recommended to put an auxiliary pump at the inlet of the mixer, and if a high discharge pressure is required, it is necessary to assemble another auxiliary pump.

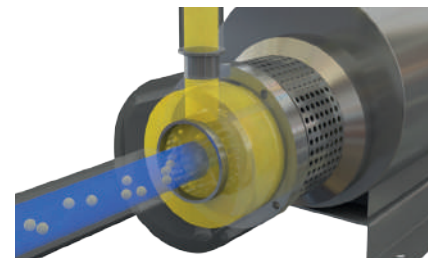
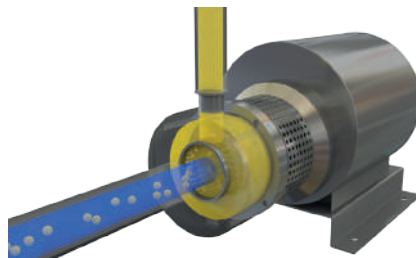
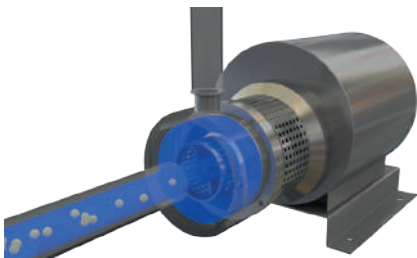
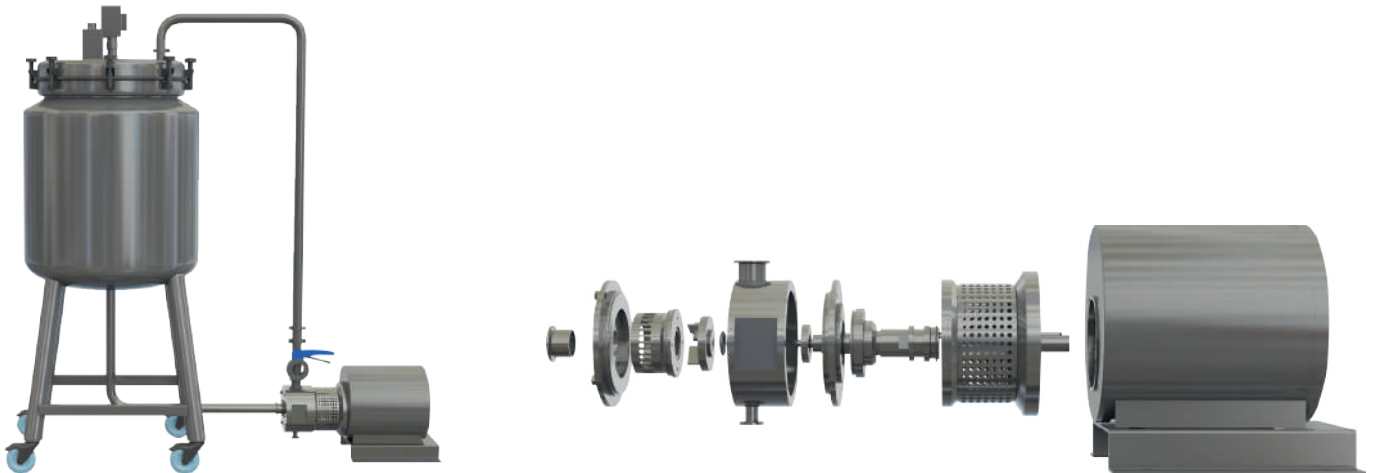

**This head is the most popular combination high shear and flow rate efficiency**



**This head is suitable for use with higher viscosity products than any other head design**



**This head used for low viscosity products**

## FIM INLINE MIXER

### DIMENSIONS

### CAPACITY

TYPE	Ø DNI	Ø DNI <sub>t</sub>	Z	B	D	E	F	G	H	I	ØJ	ØK	L	M
FIM 30-011	11/2"	11/2"	70	595	114	175	190	230	325	355	290	15	245	285
FIM 30-040	2"	2"	86	700	140	232	256	300	400	445	350	19	355	410
FIM 30-075	2 1/2"	2 1/2"	86	850	140	252	253	350	450	490	400	19	355	410
FIM 30-185	3"	2 1/2"	98	1080	175	310	227	600	700	615	500	19	465	520
FIM 15-220	4"	3"	109	1115	204	310	269	600	700	615	500	19	465	520

Flow (kg/h)	Power (kw)	Speed (rpm)
10	1,1	3000
20	4	3000
30	7,5	3000
35	18,5	3000
45	22	1500

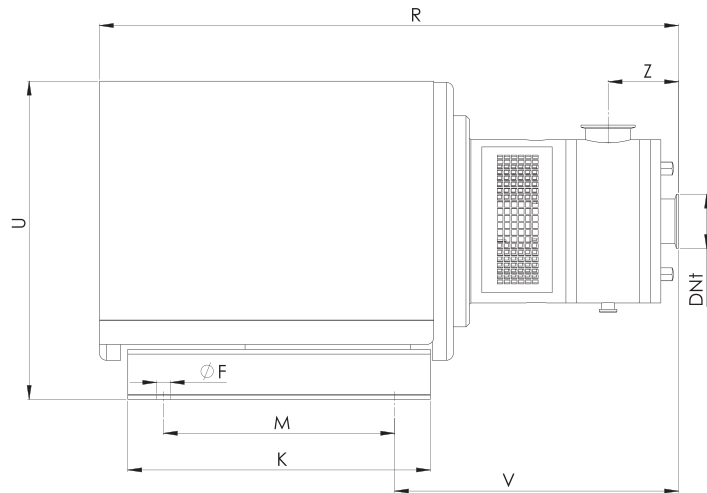
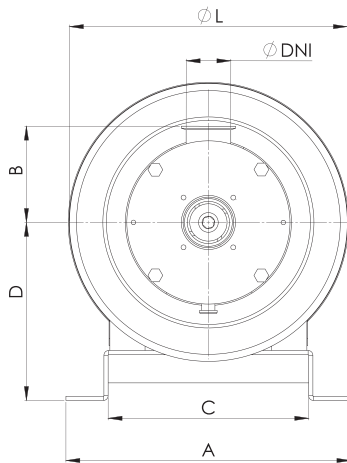

**PT BUMI TEKNIK PUSAKA ABADI**

Perum Citra Raya, Jalan Ecopolis Boulevard Utama

Ruko The Boulevard Blok P01 No. 159R, Tangerang, Banten – 15710

Phone : +62 21 5966 3552 ; Mobile : +62 812 2888 2368 ; Whatsapp : +62 878 5758 2038

Email : pt.btpa@gmail.com ; btpa.jkt@gmail.com ; marketing@btpabadi.com

Website : www.btpabadi.com